



LAWRENCE-WENTWORTH HOUSE

Lowell, Massachusetts

The Lawrence-Wentworth House, originally the home of one of Lowell's antebellum mill owners, has had numerous alterations and changes in use since its construction in 1831. Its original Greek Revival street facade was altered sometime after the Civil War to such an extent that it appears more Victorian than Greek Revival.

Beginning at the turn of the century, the single family residence was converted to a boarding house, a succession of commercial uses, and finally to offices for a social service organization. Sometime during this series of changes, the Victorian double-hung wooden sash on the first floor were replaced with mill finish aluminum jalousies as shown in the above photograph of the rear facade. The Victorian wooden sash, consisting of a two-over-two (2/2) light configuration, survived on the second floor.

After experiencing several years of sizable increases in energy costs, coupled with the inherently poor thermal performance of the jalousie sash on the first floor, the owner, Unitas, Inc., a service organization to Lowell's Hispanic community, came to the Lowell Historic Preservation Commission requesting assistance in replacing these visually obtrusive and thermally inadequate windows.

Design Problem

The Victorian 2/2 sash on the second floor were still in serviceable condition and were already fitted with storm windows. Consideration was therefore given to the installation of 2/2 replacement sash and frames on the first floor that would match the visual qualities of the remaining historic windows and at the same time incorporate the energy efficiency features of double glazing and weather stripping. Another important goal was to reduce cost without altering the appearance of the windows or affecting their performance.

Design Solution

Studies have shown that when treated with a water repellent coating, and properly fabricated and installed, new wood windows will provide long service. Since the exterior wood siding, trim, upper floor windows and painted masonry would all require periodic repainting, this maintenance consideration was not a major factor in the decision to install wooden replacement windows.

A full-scale measured drawing was made of an existing second floor window as a guide in detailing the replacement window. This investigation revealed that the single-glazed 2/2 sash were 1 $\frac{3}{8}$ " thick, and that the entire width of the box frame was exposed on the exterior.

In reaching the decision to install wooden windows, the important techni-

PRESERVATION

Tech Notes

NATIONAL PARK SERVICE
U.S. DEPARTMENT OF THE INTERIOR
WASHINGTON, D.C.

WINDOWS

NUMBER 6

Replacement Wooden Sash and Frames With Insulating Glass and Integral Muntins

Charles Parrott

Lowell Historic Preservation Commission
U.S. Department of the Interior

Replacement of missing architectural features or insensitive later replacements should be based on accurate duplication of features, substantiated by historic, physical, or pictorial evidence. The composition, design, color, texture and other visual qualities of the historic feature should be matched.

cal issue was the treatment of the vertical muntin in both the upper and lower sash. The narrow appearance of the $\frac{3}{4}$ " muntin in the historic sash presented some problems, since insulating glass was preferred for the new windows and required a wider muntin for proper installation. The alternative of using new single glazed wooden windows, with a separate interior or exterior storm unit added, was less desirable in this case since such windows would be more troublesome to open.

The selected replacement sash were designed to have two individual lights of insulating glass in each sash with an integral (as opposed to a "fake" or applied) muntin. Based on the experience gained by the Lowell Historic Preservation Commission in previous projects, the muntin of the new sash was made only 1" wide, closely matching the appearance of the historic $\frac{3}{4}$ " wide vertical muntins remaining in the upper floor windows (see figure 1). This slight change in muntin width is hardly noticeable. The results might have been different if the old and new sash had existed side by side; if the number of panes had been greater and the panes themselves been smaller; or if the historic muntins had been thinner.

The new sash were made $1\frac{3}{4}$ " thick, an increase of $\frac{3}{8}$ " over the historic sash, in order to allow a sufficiently deep rabbet in which to set the $\frac{7}{16}$ " insulating glass and to provide added support for the double weight of the glass.

Fabrication and Installation

Along with full scale working drawings for the new window, written specifications for both sash and frame fabrication and installation were prepared. These documents were sent to several window shops and installation contractors to obtain separate quotations for fabrication and installation.

The ten new windows were to be delivered fully primed and assembled. Of the ten windows, six were detailed for masonry openings and four for frame openings. No more than two windows were the same size, and there were seven different sizes in all. Only the six principal windows, averaging 21 square feet each, were of 2/2 configuration. Replacements for the four smaller jalousie windows, positioned in less prominent rear or side locations, away from the front of the building, were designed in 1/1 light configuration, but were otherwise identical to the larger windows.

Two types of a commercially-available rigid metal weather stripping, formed

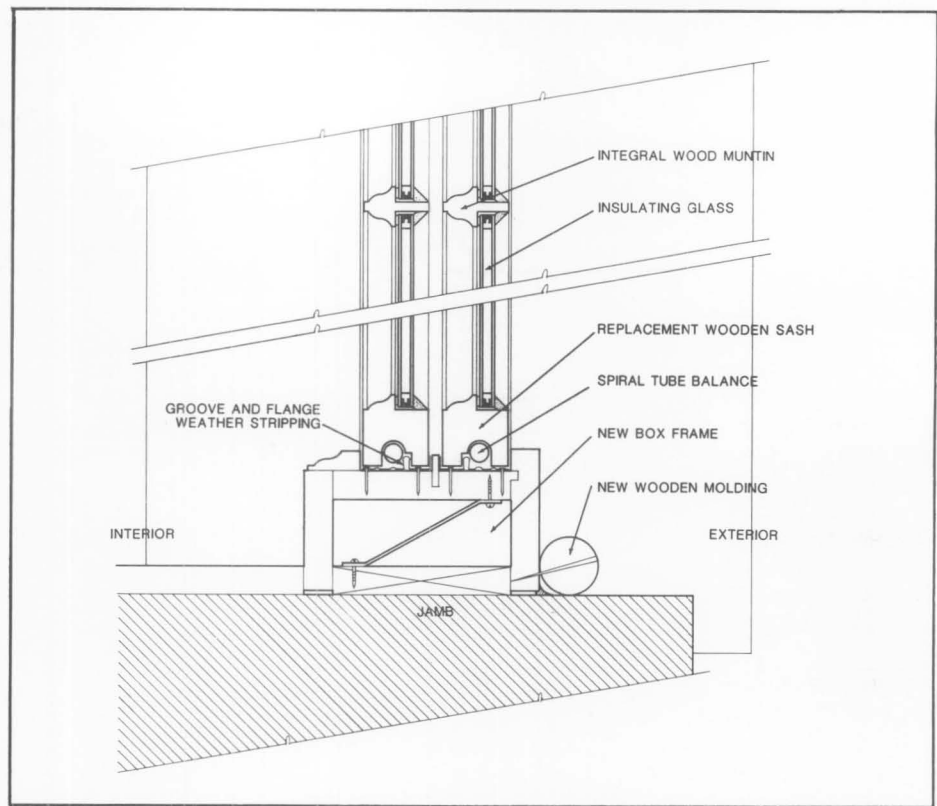

Figure 1. The wooden replacement windows had two individual lights of insulating glass in each sash with an integral (as opposed to "fake") muntin. Drawing: Penelope S. Watson

from rolled zinc sheets, were installed in preference to a less permanent vinyl, foamed plastic, or spring-metal weather stripping. At the heads, jambs and sills, the weather stripping consists of a continuous flange over which fit the grooved rails and stiles. At the meeting rail, the weather stripping consists of two interlocking hooks (see figure 2). The weather stripping protrudes only a short distance above and below the meeting rails along the jambs and is almost totally concealed when the windows are shut. It is extremely durable and is virtually unaffected by corrosion or chemical decomposition.

The sealed insulating glass units, installed in the fabricator's shop, were first caulked with a thin bead of non-hardening water-based (containing no oil) sealant. The sealant was applied at the corner of the glass unit so as not to touch the butyl compound used to seal the edge of the insulating glass (see figure 3). The water-based sealant serves as an important barrier between the separate butyl-seal on the insulating glass and the standard oil-based glazing compound as used in the actual glazing. The oil-based glazing compound was chosen in preference to the standard wood molding strips to provide a cheaper, more flexible and more weather-resistant

glazing. It also matches the historic glazing treatment.

The historic windows in the Lawrence-Wentworth House were balanced in standard fashion with sash weights and pulleys. Since many were missing on the first floor, less costly spiral tube balances were specified for the new windows (see figure 1). The spiral tube balances were attached at their top to the face of the jamb near the top of the window. The longer balance tube for the lower sash, therefore, is visible above the closed lower sash inside the building, just as the sash cord is exposed on a weight balanced sash. The tube balances, however, are not seen from the exterior and their use permitted a more energy efficient window frame. The empty boxes, which would have held the sash weights, were filled with insulation; air infiltration was further reduced since there were no pulley mortises in the frame.

The spiral balances also allowed the use of a less expensive L-shaped, shop-fabricated frame, and the look of the historic box frame was accomplished with masonry-anchored nailers, steel framing clips, and flat interior casing stock (see figure 1).

The new wooden frame was thus identical in appearance to the historic frame on the building. The width of the historic frame was reproduced along with the wooden brick molding used to trim the exterior of the masonry openings (see figure 4).

Figure 2. Several types of zinc weather stripping were used. Drawing: Penelope S. Watson

Project Costs

The ten windows were fabricated to specification, including such features as wood preservative treatment and sash locks, for \$2520 (\$13.40 per square foot).

The installation work, undertaken in 1983, included preparation of the window openings; installation of the windows and interior stops; and the attachment of exterior brick molding and all interior trim, which had been selected from flat or molded stock. Priming unprimed elements and caulking were also included in the installation work, which totaled \$1800 (\$9.52 per square foot).

Total cost of the ten windows less finish painting, which was done as part of the general exterior repainting, was \$4320 (\$22.92 per square foot). Wooden frame half screens mounted on the interior and set in aluminum tracks were also furnished and installed for a total of \$490 for the ten windows.

Project Evaluation

The window work on the Lawrence-Wentworth House shows the practicality of replacing windows on a selective basis. In replacing only the first floor windows, significant cost savings were achieved and the 2/2 Victorian windows on the second floor were saved. This project clearly shows that energy conservation and other cost-reducing measures can be achieved in replacement windows that reproduce the visual qualities of the historic windows. The use of spiral balances and insulating glass, the increase in the sash thickness, modifications to the box frames, and the slight widening of the integral wood muntin were accomplished in a sensitive way in keeping with the Secretary of the Interior's "Standards for Rehabilitation." This approach has limitations, especially when dealing with very thin historic muntins, where to accommodate the weight of insulating glass and for suitable glazing, the width of the muntin would have to be increased substantially. In many cases, however, involving two- and four-light sash, this application can be adopted without perceptibly increasing the width of the muntin or diminishing the historic character of the window.

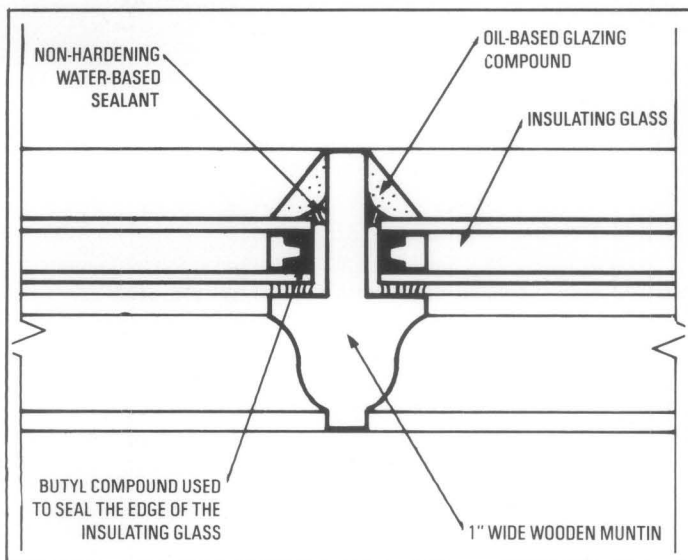
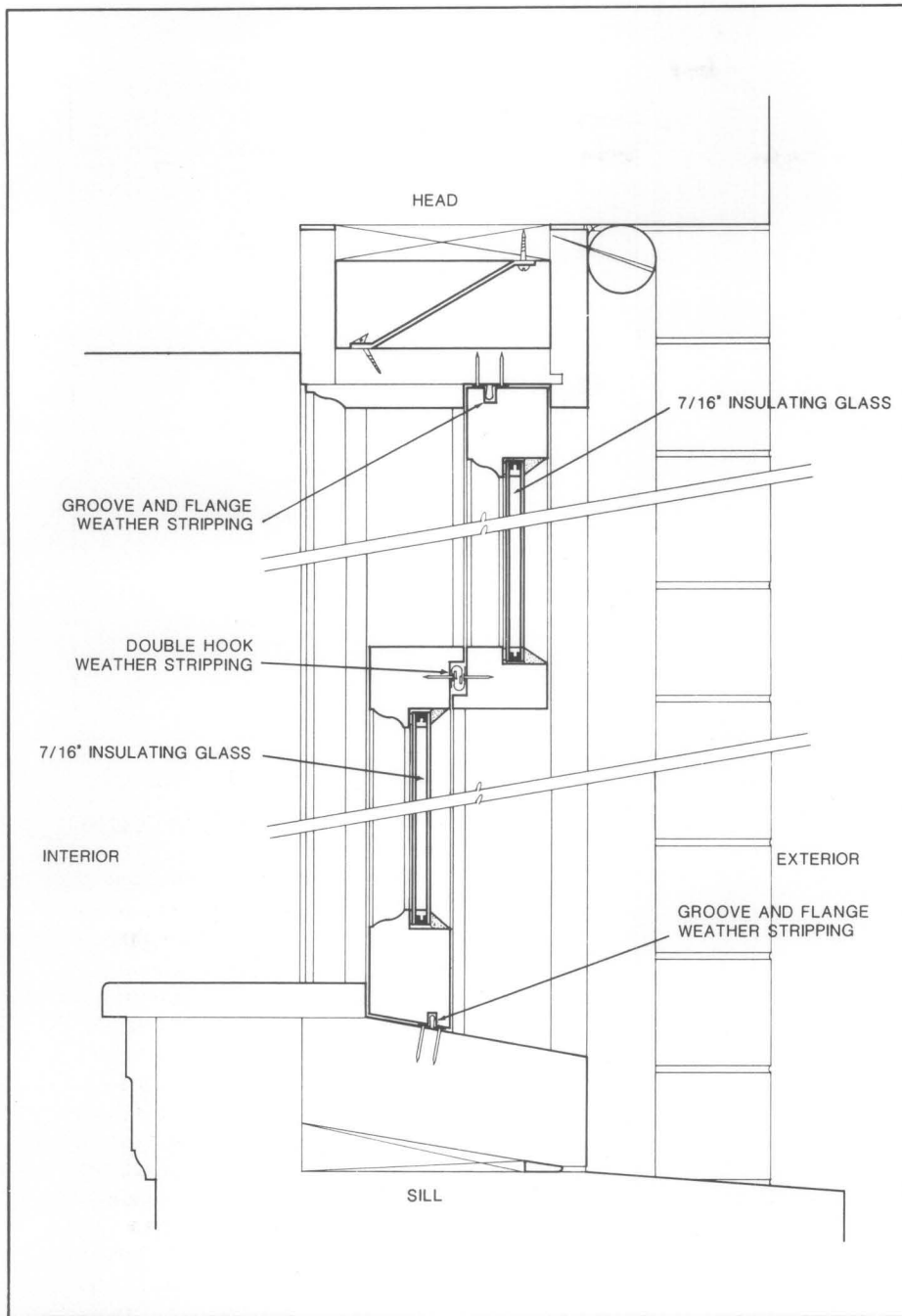

Figure 3. Glazing detail shows how the non-hardening water-based glazing sealant was used to separate the butyl compound (used to seal the insulating glass) from the oil-based glazing compound. Drawing: Penelope S. Watson



Figure 4. The new wooden windows on the first floor with insulating glass installed closely matched the historic windows which were preserved on the upper floor. Photo: Charles Parrott

This PRESERVATION TECH NOTE was prepared by the National Park Service in cooperation with the Lowell Historic Preservation Commission, and the Center for Architectural Conservation, Georgia Institute of Technology. Charles E. Fisher, Preservation Assistance Division, National Park Service, serves as Technical Coordinator for the TECH NOTES. Special thanks go to the following people who contributed to the production of this TECH NOTE: John H. Myers, Center for Architectural Conservation, Penelope S. Watson of the Lowell Historic Preservation Commission, and Preservation Assistance Division staff, particularly Michael J. Auer, Martha A. Gutrick, and Mae Simon. Photo on page 1 by Jim Higgins.

This and many of the TECH NOTES on windows are included in "The Window Handbook: Successful Strategies for Rehabilitating Windows in Historic Buildings" (available late 1984), a joint publication of the Preservation Assistance Division, National Park Service and the Center for Architectural Conservation, Georgia Institute of Technology. For information, write to The Center for Architectural Conservation, P.O. Box 93402, Atlanta, Georgia 30377.

PROJECT DATA

Building:

Lawrence-Wentworth House
48 Lawrence Street
Lowell, Massachusetts

Owner:

Unitas Inc.
48 Lawrence Street
Lowell, Massachusetts

Project date: Early 1983

Design Staff:

Lowell Historic Preservation
Commission
204 Middle Street
Lowell, Massachusetts

Fabrication:

The Window Shop
250 Chandler Street
Worcester, Massachusetts

Materials:

Weather Stripping-
Southern Metal Products
3950 Swinner Road
Memphis, Tennessee

Sash Balances-

Caldwell Manufacturing Company
64 Commercial Street
Rochester, New York

Sealed Insulating Glass-
Economy Glass Corp.
315 Columbus Avenue
Boston, Massachusetts

Project Costs:

The fabrication cost, including priming, of the 10 windows (7 different sizes) was \$2520 (\$13.40 per square foot); installation cost was \$1800 (\$9.52 per square foot); total cost was \$4320 (\$22.92 per square foot).

PRESERVATION TECH NOTES are designed to provide practical information on innovative techniques and practices for successfully maintaining and preserving cultural resources. All techniques and practices described herein conform to established National Park Service policies, procedures, and standards. This TECH NOTE was prepared pursuant to the National Historic Preservation Act Amendments of 1980 which directs the Secretary of the Interior to develop and make available to government agencies and individuals information concerning professional methods and techniques for the preservation of historic properties.

Comments on the usefulness of this information are welcomed and should be addressed to TECH NOTES, Preservation Assistance Division, National Park Service, Washington, D.C. 20240. This publication is not copyrighted and can be reproduced without penalty. Normal procedures for credit to the author and the National Park Service are appreciated.